

FOBA studio backgrounds, shooting tables and lamp stands. A big range of professional equipment.

FOBA[®]
STUDIO-TECHNOLOGY

Studio accessories – all around the subject

FOBA supplies complete systems for professional photographers. FOBA's main claim to fame include the FOBA **COMBITUBE*** modular system, FOBA stands, tripods and heads, and FOBA ceiling rail systems **ROOF-TRACK** and **MEGA-TRACK**. However, FOBA also carries a comprehensive array of useful studio equipment:

FOBA shooting tables

Good studio tables take the hard work out of photography. FOBA carries three table types, designed by experienced specialists to satisfy even the most exacting photographer's requirements. Cast shadows are effectively neutralized, even with complex multiple lighting. FOBA tables harmonize perfectly with the well-known **COMBITUBE*** system, and therefore profit from this system's many modular components: lights and accessories can be set up, displaced or removed in no time at all, extensions are a mere twist or two away – and the surrounding floor space remains uncluttered. The preformed, undulated acryl sheets are just ideal for shooting blended backgrounds and floating objects, considerably reducing processing time and therefore costs.

FOBA backgrounds

There is more behind good photography than lighting alone. FOBA keeps the background in mind and offers not only a wide selection of colourful background papers in three different widths, but also a versatile range of unrollers and stands to suit.

FOBA lamp stands

FOBA lamp stands are based mainly on the worldwide renowned, modular **COMBITUBE*** system. This gives them multiple functionality and great flexibility. There is almost no light position which cannot be achieved with one of FOBA's several lamp stand.

FOBA products are

- modular
- durable
- versatile

which means

- pleasant working conditions
- efficiency
- profitability

FOBA products are made in Switzerland according to the company's traditional manufacturing methods. First-class materials are processed with craftsmanship. FOBA's legacy of successful studio equipment guarantees practical, efficient products.



* Visit www.foba.com to learn more about FOBA's practical COMBITUBE system

A variety of mobile or fixed roll stands are available for FOBA background papers.

FOBA supplies a wide variety of background material, either in rolls or as individual sheets.

Design with light with FOBA studio lamp stands. Their modularity makes them incredibly versatile.

FOBA shooting tables have proven their worth over the years. The preformed acrylic sheets are just perfect to achieve blended and camaieu picture backgrounds, as well as shooting floating subjects.

Most products listed in this brochure are in matte black.

FOBA shooting tables can be fitted with casters for effortless transportation around the studio.

The good life in an orderly studio

FOBA solves your background setup problems – with devices that have proven their worth in the best studios. Mobile or fixed background unrollers, easy to use and reliable, yet gentle to your paper backgrounds.



DODRE

Triple unrolling device for wall or ceiling mounting, consists of:

- 1 DORPO triple hook strips
- 3 DAPAO clamping devices
- 3 DAPSO trailing edge strips for paper width 2.75 m

Weight: 11 kg (24 lb)



Install DAPAU rubber cleats on clamps to use them with cardboard cores with inner Ø up to approx. Ø 63 cm.



DORPO

Pair of triple hook strips, hooks in descending length, for ceiling or wall fastening.

Length:	33.5 cm
Shortest hook:	12.0 cm
Longest hook:	19.5 cm
Weight:	2.0 kg (4.4 lb)



DORPA

Pair of triple hook strips, hooks of equal length, for ceiling fastening. Especially for low-ceilinged studios.

Length:	33.5 cm
Hook:	12.0 cm
Weight:	1.7 kg (3.8 lb)



DORPE

Pair of hooks for wall or ceiling fastening.

Hook:	12.0 cm
Weight:	470 g (1 lb)



DAPAO

Complete clamping device for background paper rolls with cardboard core, sturdy aluminium build. Consists of:

- 1 pair of clamp inserts for core Ø 46 - 60 mm
- 1 DUPEE chain wheel
- 1 DUPIE chain
- 1 DABRO brake

Weight: 1,5 kg (3.3 lb)

For larger inner core Ø up to 63 mm, use DAPAU rubber cleats. Special clamps for larger cores are available on request.

Generous distance between twist grip and clamp (approx. 10 cm) makes for easy assembly and operation.



DAPAA Pair of clamp inserts for unrollers, with brake, as used in DAPAO, but without wheel and chain (available separately).

Weight: 770 g (1,7 lb)



DUPEE Separate chain wheel for DAPAO/DAPAA clamps, plastic.

Weight: 70 g (0,2 lb)



DUPIE Separate chain for DAPAO/DAPAA clamps.

Length: 196 cm
Weight: 650 g (1.4 lb)



DABRO Separate plastic bearing with friction brake for DAPAO/DAPAA clamps.

Prevents paper from unrolling accidentally. Braking friction can be set with a screw according to paper weight. Hole for Ø 18 mm rods.

Weight: 40 g (0.09 lb)



DAPAU Rubber cleats for DAPAO/DAPAA clamp, set of 6. Increases DAPAO/DAPAA application range to tubes with inner Ø up to approx. 63 mm.

Length: 11 cm
Weight: 60 g (0.13 lb)

Unrolling devices in modular concept

DAPAO/DAPAA clamps are inserted directly in the cardboard paper roll core. The wider the paper, the more rolls tend to sag in the middle after some time. Expensive background paper might easily get damaged.

DAPOA/DAPOI steel tube within the core will keep it from sagging. Cones inserted in the tube's extremities will keep cardboard core and tube rolling together as a unit when the chain wheel is turned.

Like most FOBA products, unrollers are modular in concept: **DAPAO** clamping device can be upgraded to maximum comfort at any time by adding steel tube and cones, thus keeping up with the photographer's requirements.

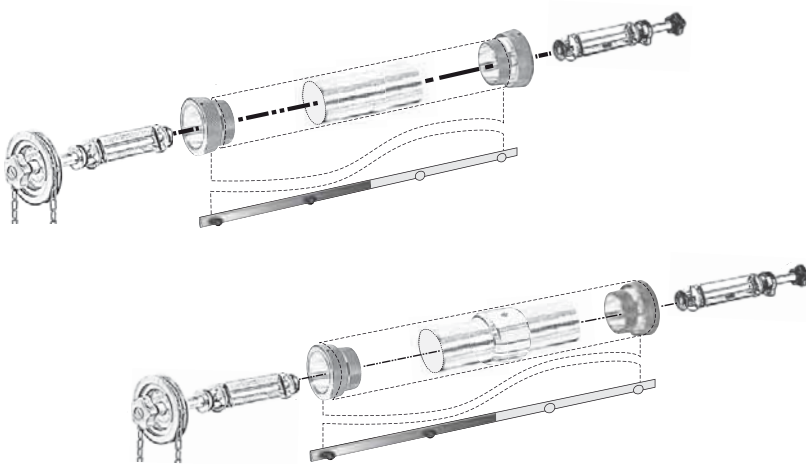

Paper backgrounds on roll

Various colours according to reference/colour chart **B2000** (or at www.foba.com)

Product n°	B1xx1*	B1xx0*	B1xx3*
Paper width or roll length	1.35 m	2.75 m	3.55 m
Paper length	11 m	11 m	32 m
Inner Ø of cardboard core	54 mm	54 mm	67 mm
Weight	2.4 kg (5.3 lb)	4.8 kg (10.6 lb)	19.0 kg (41.9 lb)

* xx indicates the colour code according to chart B2000

FOBA product range also include plastic sheeting. For more information of FOBA's **TT Plast** range, please refer to this brochure's back cover page.



Steel tube for background paper rolls. Prevents sagging of the cardboard core and damage to the paper.

DAPOA

For paper width:	2.75 m
Inner Ø:	47 mm
Outer Ø:	50 mm
Length:	2.845 m
Weight:	4.8 kg (10.6 lb)

DAPOI

For paper width:	3.55 m
Inner Ø:	47 mm
Outer Ø:	50 mm
Length:	3.595 m
Weight:	6.0 kg (13.2 lb)



DAPOE

Roll holder fittings, set of 2 cones for paper width 2.75 m, correspond to **DAPOA** steel tube. Ensure that paper roll and steel tube rotate together.

Inner Ø:	50.5 mm
Weight:	205 g (0.45 lb)

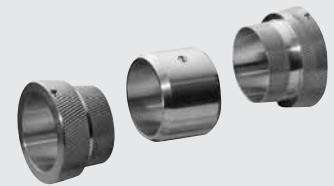

DAPOR

Roll holder fittings, set of 2 cones and 1 cylinder for paper width 3.55 m, correspond to **DAPOI** steel tube. The cones ensure that paper roll and steel tube rotate together; the middle cylinder keeps the cardboard core from sagging onto the steel tube.

Inner Ø:	50.5 mm
Weight:	310 g (0.7 lb)



Aluminium trailing edge strip for background papers, in two pieces. Helps to keep paper flat on the floor, reducing paper scuffing and wear.

DAPSI

For paper width:	1.35 m
Length:	1.30 m
Weight:	0.7 kg (1.5 lb)

DAPSO

For paper width:	2.75 m
Length:	2.75 m
Weight:	1.4 kg (3.0 lb)

DAPSE

For paper width:	3.55 m
Length:	3.50 m
Weight:	1.8 kg (3.95 lb)



DASRO
 Mobile stand for 2 unrollers
 (rolling device **DAPAO** not included)
 For paper width 2.75 m

Min. height:	2,2 m
Max. height:	3,5 m
Stand width:	3,1 m
Caster Ø:	74 mm
Weight:	approx. 30 kg (66 lb)

Top DASRO equipment
 To make the most out of your mobile unroller stand, we recommend:

- 2 **DAPOA** steel tube
- 2 **DAPOE** fittings
- 2 **DAPAO** clamping device
- 2 **DAPSO** trailing edge strip

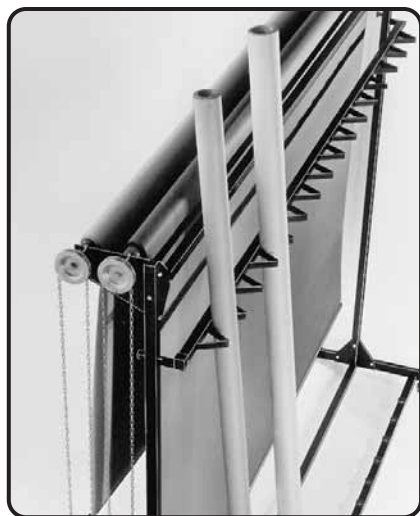

You can carry up to 15 background paper rolls around on **DASRO**. They fit nicely in the roll holder at the back.

Mobile roll stand made with **COMBITUBE*** elements. Width according to use. Easy to assemble, light and handy, just right to take along on field work.

Parts required for this particular build:

- 2 **COSTO/COSNO AS** folding tripods
- X **COMBITUBE** (**CONRO**, **COKRO**, etc.) according to height
- 2 **CEHUO** tapped sleeves
- 2 **CORPO** fork pieces
- 1 **DAPAO** clamping device with chain
- 1 **DAPSI**, **DAPSO** or **DAPSE** trailing edge strip, according to paper width



CORPO
 Fork holder for **DAPAO/DAPAA** clamps on **COMBITUBE*** elements. Bottom 3/8" tap. Interchangeable installation on **COMBITUBE*** elements with tapped sleeve **CEHUO**.

Weight: 125 g (0.3 lb)



CEHUO
 Sleeve for various interchangeable adapters (see page 13), among others fork holder **CORPO**.

Female **COMBITUBE*** 3/8" connector at bottom.



Assembly detail of mobile **COMBITUBE** roll stand with clamping device **DAPAO**, fork holder **CORPO** and adapter sleeve **CEHUO**.

* Visit www.foba.com to learn more about FOBA's practical **COMBITUBE** system

No shadows on your work

FOBA shooting tables are born of photographer's practical experience and of their quest for perfect lighting conditions to reduce or even eliminate burdensome retouching. The result: FOBA tables are equipped with a special synthetic surface, processed to colourlessness and mattness and rendered entirely non-reflecting through complex treatment. The surface is frosted for absolutely uniform transparency.

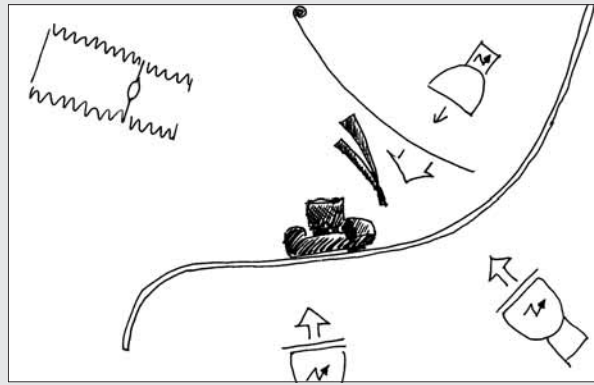

True colours

FOBA acryl sheets are colourless and ensure uniform transparency with both flash and constant light.

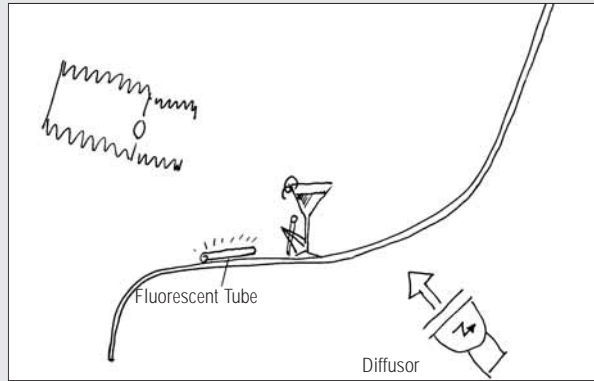

Fade and blend

FOBA tables are equipped with preformed sheets, so shooting blended or fading backgrounds becomes easy. Coloured light filters allow the photographer to create interesting effects.

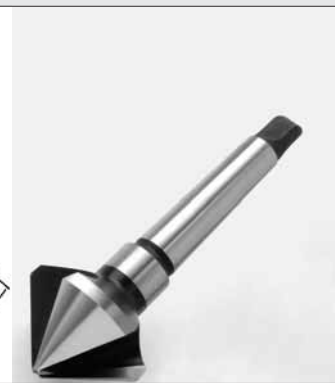
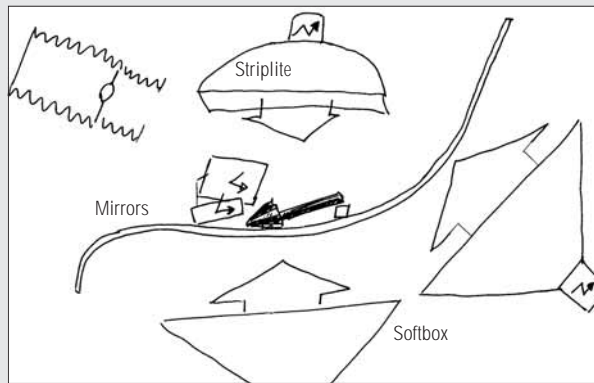

No shadows anywhere

No part of the FOBA tables aluminium frames crosses the front of the acryl sheet. This characteristic, together with the sheet's curved front, make shadow-free frontal shots possible – a great plus.

COMBITUBE* makes it happen

FOBA's table frames are equipped on the sides and top with COMBITUBE 3/8" connections. Help yourself to the advantages of FOBA's modular, versatile COMBITUBE* system elements to position lamps, screens, or the subject itself on the table – and without taking up any floor room, either.

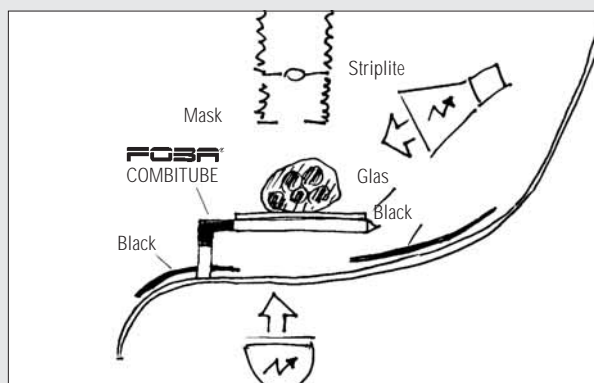
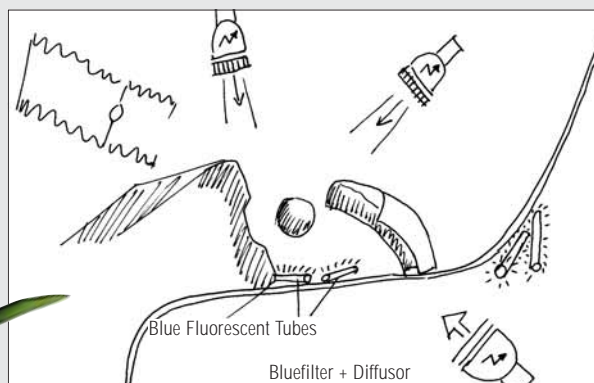

Illustrations: D. Savini

* Visit www.foba.com to learn more about FOBA's practical COMBITUBE system

There's more

To make the most out of your FOBA table, a large choice of additional equipment is available, for instance:

- acryl diffuser cones and tunnels
- **TT Plast** sheets in various colours
- **COMBITUBE*** elements to set up lamps, filters or the subject itself. All FOBA tables are equipped with **COMBITUBE*** adapters.
- casters for more mobility in the studio.

FOBA tables undisputed usefulness is due partly to the diversity and number of accessories available.



DIDRI

Separate acryl sheet for shooting table **DIMIU**

Width:	90.5 cm
Length:	100 cm
Thickness:	3 mm
Max. load (distributed):	approx. 25 kg (55 lb)
Weight:	4.2 kg (9.3 lb)

All advantages at a glance:

- colourless, matte acryl sheets
- preformed for shadowless shots
- sturdy
- large choice of accessories



DIMIL, detail view of the sheet tilting device which allows the top of the sheet to be fixed any position from upright to flat.

DAPLE

Separate acryl sheet for shooting table **DIMIL**.

Width:	123 cm
Length:	170 cm
Thickness:	3 mm
Max. load (distributed):	approx. 20 kg (44 lb)
Weight:	8.0 kg (17.6 lb)

DIMIE

Separate frame for shooting table **DIMIL**, hollow 25 x 25 mm aluminium tubes.

Weight:	6.6 kg (14.5 lb)
---------	------------------



DIMIU

Shooting table, small. Preformed acryl sheet, front and back undulations. Especially designed for smaller studios, easy to assemble and take apart, light, takes up little room.

Consists of:

- 1 **DIDRI** acryl sheet
- 1 **DIDRU** aluminium tube frame

Sheet thickness:	3 mm
Flat surface:	80 x 45 cm
Width:	90.5 cm
Length:	84 cm
Flat surface height (no casters):	71.5 cm
Max. load (distributed):	approx. 25 kg (55 lb)
Weight:	8,4 kg (19 lb)

DIDRU

Separate frame for shooting table **DIMIU**, hollow 25 x 25 mm aluminium tubes.

Weight:	4.2 kg (9.3 lb)
---------	-----------------



COLRI

Caster for **DIMIL** and **DIMIU** tables, with brake, set of 4.

Increases table height by approx.	7.5 cm
Caster Ø:	50 mm
Weight:	185 g/unit (0.4 lb/piece)

DIMIL

Shooting table, middle size. Sheet back can be tilted by 90°, front part preformed. Adjustable back rungs. The upper rung can be set in 5 different positions to follow the sheet angle; bottom rung has 3 positions to allow floor lights comfortably through.

Consists of:

- 1 **DAPLE** acryl sheet
- 1 **DIMIE** aluminium tube frame (**COLRI** casters not included)

Sheet thickness:	3 mm
Flat surface:	120 x 50-140 cm
Width:	123 cm
Length:	110 - 197 cm
Flat surface height (no casters):	75 cm
Max. load (distributed):	20 kg (44 lb)
Weight:	15,7 kg (34 lb)

* Visit www.foba.com to learn more about FOBA's practical **COMBITUBE** system

FOBA acryl sheets are performed in simple or double undulation (see table hereafter). They can do more than just lay on a table: set sideways (e.g. between 2 upright COMBITUBE on **CESRA** base), they make effective vertical screens whose form can be used to create interesting lighting effects on the objects.

Large FOBA shooting tables are equipped with preformed sheets with double undulations. Sturdy side brackets are equipped with COMBITUBE* connectors, where any of this well-known system's elements can be installed.

Flat acryl sheet **DAPLU** is available separately to protect the table's own sheet from damage.



Large shooting table **DIGRO**, consisting of:

- 1 **DOPLE** preformed acryl sheet
- 1 **DOPLO** side brackets pair
- 4 **CONRO AS** 80 cm COMBITUBE*
- 12 **CODEA** right-angle connectors
- 4 **COGUO** rubber stoppers
- 4 aluminium tubes 1185 mm
- 2 aluminium tubes 775 mm
- 2 aluminium tubes 940 mm with top COMBITUBE* connector

Technical information:

Sheet thickness:	6 mm
Flat surface:	123 x 105 cm
Width:	130 cm
Length:	approx. 180 cm
Flat surface height (no casters):	87 cm
Max. load (distributed):	approx. 60 kg (132 lb)
Weight:	50 kg (110 lb)

Large shooting table **DIBRO**, consisting of:

- 1 **DIBRE** preformed acryl sheet
- 1 **DOPLO** side brackets pair
- 4 **CONRO AS** 80 cm COMBITUBE*
- 14 **CODEA** right-angle connectors
- 4 **COGUO** rubber stoppers
- 5 aluminium tubes 1485 mm
- 2 aluminium tubes 775 mm
- 2 aluminium tubes 940 mm with top COMBITUBE* connector

Technical information:

Sheet thickness:	6 mm
Flat surface:	153 x 105 cm
Width:	160 cm
Length:	approx. 180 cm
Flat surface height (no casters):	87 cm
Max. load (distributed):	approx. 60 kg (132 lb)
Weight:	58 kg (128 lb)

Dimensions of FOBA acryl sheets. Values L1-L7, r, α are approximate.

Type of the shooting table	Name of the table	Acryl sheets													
		Name	Width of plate	Operational width	Thickness	L1 cm	L2 cm	L3 cm	L4 cm	L5 cm	L6 cm	L7 cm	r cm	α	
Small, Type A	DIMIU	DIDRI	90.5 cm	90 cm	3.0 mm	100	17	50	33	48	31	16	23	50°	
Med., Type B	DIMIL	DAPLE	123 cm	120 cm	3.0 mm	171	25	-	-	146	-	25	35	-	
Large, Type A	DIGRO	DOPLE	130 cm	123 cm	6.0 mm	200	22	100	78	99	83	27	37	60°	
	DIBRO	DIBRE	159 cm	152 cm	6.0 mm	200	26	104	78	99	83	27	37	60°	

Type A

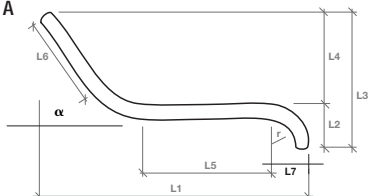

Type B

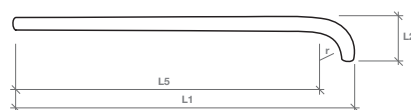

Acryl sheets being flexible, table and sheet dimensions in this catalogue are approximate.

DOPLE

Separate acryl sheet for shooting table **DIGRO**.

Width:	130 cm
Length:	200 cm
Thickness:	6 mm
Max. load (distributed):	approx. 60 kg (132 lb)
Weight:	23 kg (51 lb)

DIBRE

Separate acryl sheet for shooting table **DIBRO**.

Width:	160 cm
Length:	200 cm
Thickness:	6 mm
Max. load (distributed):	approx. 60 kg (132 lb)
Weight:	29 kg (64 lb)



DOPLO

Separate side brackets pair for shooting tables **DIGRO** and **DIBRO**, with 4 COMBITUBE* connectors per bracket.

Length:	120 cm
Weight:	6.6 kg (14.5 lb)



COLRU

Separate castor for shooting tables **DIGRO** and **DIBRO**. Increases table height by approx. 10 cm.

Caster \varnothing :	50 mm
Weight:	300 g (0.7 lb)

* Visit www.foba.com to learn more about FOBA's practical COMBITUBE system

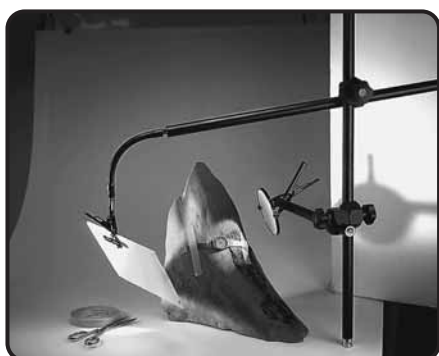

Swivel arm **CAMUN**, a couple of other **COMBITUBE*** elements. This simple combination will help you master the most complex setups.



Articulated 360° clamp **COGEU** gives the swivel arm great, continuous mobility. Sliding weight **CEGOU** counterbalances even heavy loads. Safety ring **CEGEE 25**, at the end of the **COMBITUBE**, prevents the weight from sliding off accidentally.



Set up filters, mirrors and other flat objects quickly and easily, and remove them just as fast. The touch fastening makes it possible. In a nutshell: a small but very useful helper on your shooting table.



Acryl diffuser tunnels, just right for FOBA tables. Suppress shadows and reflected light effectively.

DAPLI

Acryl diffuser tunnel for **DIMIU** small sized table

Thickness:	3 mm
Length:	78 cm
Width:	47 cm
Height:	41 cm
Weight:	2.1 kg (4.7 lb)

DAPLO

Acryl diffuser tunnel for **DIMIL** middle sized table

Thickness:	3 mm
Length:	99 cm
Width:	55 cm
Height:	48 cm
Weight:	3.5 kg (7.8 lb)

The following products of **COMBITUBE*** elements, alone or assembled, bring additional functionality to FOBA shooting tables and facilitate the setting up for shooting sessions, without taking up any additional floor space. They can be extended or modified with further modular **COMBITUBE*** elements, thereby opening almost unlimited possibilities.

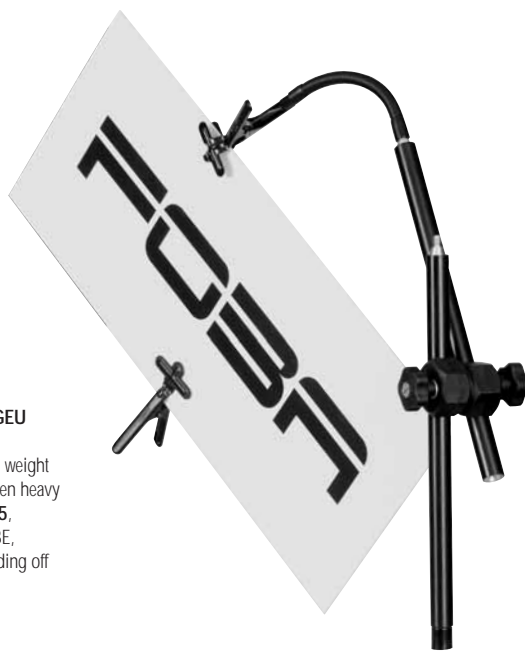

CAMUN

Swivel arm, to be fixed directly onto the shooting table (also called table-top arm). Swivels in steps of approximately 7°.

- Consists of:
- 2 **COKRO AS** 40 cm **COMBITUBE***
 - 1 **COGEA** articulated universal clamp
 - 1 **COFLO** flexible arm 20 cm
 - 1 **COKLE** **COMBITUBE*** clamp, tapped 3/8"
 - 1 **COKLO** **COMBITUBE*** clamp

Weight:	1.2 kg (2.6 lb)
---------	-----------------



COMEN

Flexible arm with touch fastening plate.

- Consists of:
- 1 **CEBRO** small support plate
 - 1 **COFLO** flexible arm 20 cm
 - 1 **COFLA**, touch fastening plate with 8 pile tabs (**COFLE**)

Weight:	1.37 kg (3 lb)
---------	----------------



COFLA

Separate touch fastening plate, tapped 3/8", including 8 adhesive pile pads (**COFLE**).

Weight:	40 g (0.1 lb)
---------	---------------

* Visit www.foba.com to learn more about FOBA's practical **COMBITUBE** system

Perfect light

FOBA acryl cones and tunnels let you shoot shiny subjects without shadows or reflexes, but also without complex lighting. They are a great help when shooting pictures for catalogues or ads, replacing complicated and often improvised lighting rigs.



DUPLI

Acryl diffuser cone, small.

Height:	21,5 cm
Top Ø:	11 cm
Base Ø:	19,5 cm
Weight:	430 g (0.9 lb)



DUPLU

Acryl diffuser cone, large.

Height:	50 cm
Top Ø:	25 cm
Base Ø:	50 cm
Weight:	2,1 kg (4.6 lb)



Shooting setup with small cone **DUPLI**. The camera is supported by table clamp stand **ASNEO** with tilting head **ASMIO**.



A nice, soft light effect achieved with large diffuser cone **DUPLU**.



DAPLU

Acryl sheets can be used for special light effects and are quite useful in the studio. They can be placed horizontally above or underneath the subject, but also vertically as here (COMBITUBE* elements available separately). FOBA acryl sheets are colourless, one surface is frosted.

Length:	123 cm
Width:	100 cm
Thickness:	3 mm
Weight:	3.8 kg (8.4 lb)



DITRE

Non-reflecting velvet-like background, matt black.

Width:	1.32 m
Length:	5.9 m
Cardbord core, inner Ø:	54 mm
Weight:	1.7 kg (3.7 lb)



DITRO

FOBA diffuser sheet, opaline.

Width:	1.37 m
Length:	5.4 m
Thickness:	0.26 mm
Cardbord core, inner Ø:	54 mm
Weight:	2 kg (4.4 lb)

* Visit www.foba.com to learn more about FOBA's practical COMBITUBE system

Reliability afoot

Most of FOBA's several lamp stands are based on the well-known modular COMBITUBE* system. They are available on flat supports, casters or folding tripods. The tubes come in either 30 mm or 25 mm diameter. Most are equipped with a sliding clamp bracket; lamps can be lifted, lowered or turned full circle with just one hand. They can also be set on top of an upright with one of an interchangeable sleeve.

Of course, all advantages of the COMBITUBE* system are also available for the FOBA lamp stands. Add, remove or replace filters, diffusers and other equipment quickly and easily.

The modular concept of FOBA's equipment has proven its worth over decades. FOBA lamp stands, sturdy and reliable, are easily modified to suit any specific activity, and are also multifunctional – a considerable plus for efficiency but also, and not least, for economy.

Lamp stands supports at a glance



Even yoked lamps can be attached on an upright COMBITUBE with top plate **CESTA**.



Close-up of top plate **CESTA** on an upright COMBITUBE.



Close up of **STARE** dolly. A strong clip spring clasps the COMBITUBE* almost all the way round without damaging it.

FOBA lamp stands give you more:

- more flexibility
- more modularity
- more mobility

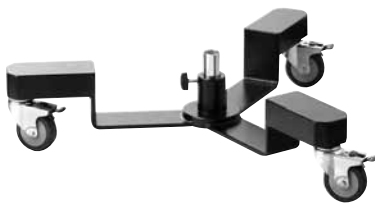

CESRO

Dolly, large model. Used for both high settings (up to 3 m) and floor positions. Casters equipped with brakes. Occupies floor space corresponding to a 60 cm isosceles triangle. For Ø 30 mm tubes; sleeve for Ø 25 mm tubes or COMBITUBE* included.

Height:	13 cm
Caster Ø:	74 mm
Weight:	18 kg (35.2 lb)



CESRA

Large support plate with handle and male COMBITUBE* connector. Protective felt underlay. No legs make it handier than a tripod.

Diameter:	26.5 cm
Plate height:	23 mm
Weight:	10 kg (22 lb)



STARE

Small dolly, especially to place lamps close to the floor and still be able to move them around. Includes COMBITUBE* 6 cm **COTMA CL**. Occupies floor space corresponding to a 38 cm isosceles triangle. For Ø 25 mm uprights.

Height:	11 cm
Caster Ø:	50 mm
Weight:	4.09 kg (8.8 lb)
(COTMA CL included)	



COSTO

Folding COMBITUBE* heavy duty tripod, black steel. For tubes Ø 25 mm.

Height folded:	95 cm
Weight:	3.1 kg (6.8 lb)



COSNO AS

Folding COMBITUBE* lightweight tripod, black aluminium. For tubes Ø 25 mm.

Height folded:	65 cm
Weight:	760 g (1.7 lb)

* Visit www.foba.com to learn more about FOBA's practical COMBITUBE system

Lamp holders

The FOBA product range includes 2 lamp holders (sliding clamp bracket, exchange sleeve) corresponding to a large selection of interchangeable adapters. They make moving lamps or changing setups quick and easy.

FOBA interchangeable adapters at a glance:

CEBLA	for Broncolor lamps
CEBLI	general lamp adapter 5/8"
CEBLO	with 1/4" - or 3/8" thread
COLBE	3/8" thread with wing nut
CEONA	8.5 cm extension
CEPRO	with adjustable hook
CORPO	fork (cf. page 6)

SAONO

For Ø 30 mm tubes
Distance mid-tube to mid-sleeve: 21 cm
Front sleeve inner Ø: 18 mm
Weight: 620 g (1.4 lb)

CEONO

For Ø 25 mm tubes and COMBITUBE*
Distance mid-tube to mid-sleeve: 21 cm
Front sleeve inner Ø: 18 mm
Weight: 680 g (1.5 lb)

Lamp stand uprights at a glance



Sleeve for various interchangeable adapters.

The bottom has either a female COMBITUBE* connector (cone and 3/8" tap) or a simple 3/8" tap; therefore, it can be installed onto lamp stand uprights (COMBITUBE* element or STAPI telescopic upright).

Inner Ø, top: 18 mm	
CEHUA	CEHUO
Bottom tapped 3/8"	Female COMBITUBE* connector (cone and 3/8" tap) below
Height: 4 cm	Height: 5 cm
Weight: 100 g (0.2 lb)	Weight: 130 g (0.3 lb)



CEONO/SAONO

Sliding clamp bracket with trigger, smooth and continuous movement.

The front sleeve can be fitted with FOBA's large range of interchangeable adapters and holders.

SANRO 2 / SANRO 3

Separate stainless steel upright

Length:	2 m / 3 m
Outer Ø:	30 mm
Weight:	2.6 kg (5.7 lb) / 4.0 kg (8.8 lb)

COMBITUBE

Steel or aluminium tubes with one male and one female COMBITUBE* connector (cone and 3/8" thread or tap). In theory, there is no limit to the length attached COMBITUBES can reach. Aluminium tubes are anodized black, steel tubes are nickel-plated silver.

Five standard lengths are available:

	alu	steel
COKTO	160 cm COKTO AS	COKTO CL
CONRO	80 cm CONRO AS	CONRO CL
COKRO	40 cm COKRO AS	COKRO CL
COARO	20 cm COARO AS	COARO CL
COTMA	6 cm COTMA AS	COTMA CL

STAPI

Telescope tube, 3 elements. Female COMBITUBE connector at bottom, therefore extendable with COMBITUBE* from below. Top with lamp adapter and additional 3/8" thread. Lower tube contains a shock-absorbing spring.

Lower element Ø:	25 mm
Extension:	95 cm – 230 cm
Weight:	860 g (1.9 lb)

Lamp stands

Interchangeable adapters for sliding brackets SAONO/CEONO, extension CEONA and sleeves CEHUA/CEHUO



CEBLA
Adapter for Broncolor lamps.

Top:	3/8" thread
Bottom:	3/8" tap
Length:	8 cm
Weight:	80 g (0.02 lb)



CEBLI
All-purpose lamp adapter, 5/8"

Length:	7 cm
Weight:	120 g (0.25 lb)



CEBLO 3/8" / CEBLO 1/4"
Interchangeable adapter with 3/8" or 1/4" thread. Tighten with a metal point through the hole.

Length:	3 cm
Weight:	60 g (0.1 lb)



COLBE
Interchangeable adapter with 3/8" thread and wing nut, to attach various components.

Length:	5.5 cm
Weight:	85 g (0.19 lb)



CEONA
Sliding bracket extension. The front sleeve takes the same interchangeable adapters and holders as CEONO/SAONO brackets.

Extension:	8.5 cm
Weight:	325 g (0.71 lb)



CEPRO
Interchangeable adapter with adjustable and removable hook.

Height:	5 cm
Hook length:	12 cm
Weight:	160 g (0.3 lb)

* Visit www.foba.com to learn more about FOBA's practical COMBITUBE system

Commonly used assemblies

FOBA keeps the most current base, uprights and lamp holder combinations at the ready in practical sets with a single order number.



STARI 2 / STARI 3

Mobile lamp stand on braked dolly, very stable and yet easy to move around.

Kit consists of:

- 1 **CESRO** heavy duty dolly
- 1 **SANRO** stainless steel upright, Ø 30 mm, (STARI 2: 2 m, STARI 3: 3 m)
- 1 **SAONO** sliding clamp
- 1 **CEBLI** all-purpose lamp adapter

Caster Ø:	74 mm
Weight STARI 2 :	21 kg (44 lb)
Weight STARI 3 :	22.7 kg (50 lb)

COMON

Lamp stand on plate with sliding clamp for quick and precise lamp positioning. Useful for placing lights low down (20 cm above the floor) or up to 1.6 m. Can be extended with additional COMBITUBES*.

Kit consists of:

- 1 **CESRA** round support, large
- 2 **CONRO AS** 80 cm COMBITUBE
- 1 **CEONO** sliding clamp bracket
- 1 **CEBLI** all purpose lamp adapter

Height:	1.65 m
Weight:	12 kg (24 lb)



STAPU

Adjustable stand, on folding aluminium tripod. Telescopic upright with shock-absorbing spring. Can be extended by adding COMBITUBES from below.

Kit consists of:

- 1 **COSNO AS** folding lightweight tripod
- 1 **STAPI** telescopic upright

Height, open:	2.4 m
Length, closed:	0.95 m
Weight:	1.62 kg (3.6 lb)



Lamp stand **COMON**, caught getting very close to shooting table **DIMIL**

More modular lamp stand assemblies



Round support **CESRA** with telescopic upright **STAPI**.



COMBITUBE* **COKTO AS** with sliding clamp **CEONO**, on folding heavy duty tripod **COSTO**.



Telescopic upright **STAPI** on small **STARE** dolly, with weight **CESRU** added for additional stability.



The low-down on lamp stands: baby COMBITUBE* **COTMA**, topped with lamp adapter **RODEE**, is set on a small **STARE** dolly.

* Visit www.foba.com to learn more about FOBA's practical COMBITUBE system

Don't take our word for it:

Dolly STARE is a telling example of the modularity and versatility of FOBA products.

Visit www.foba.com to learn more about FOBA's practical COMBITUBE system

All-purpose mobile stand

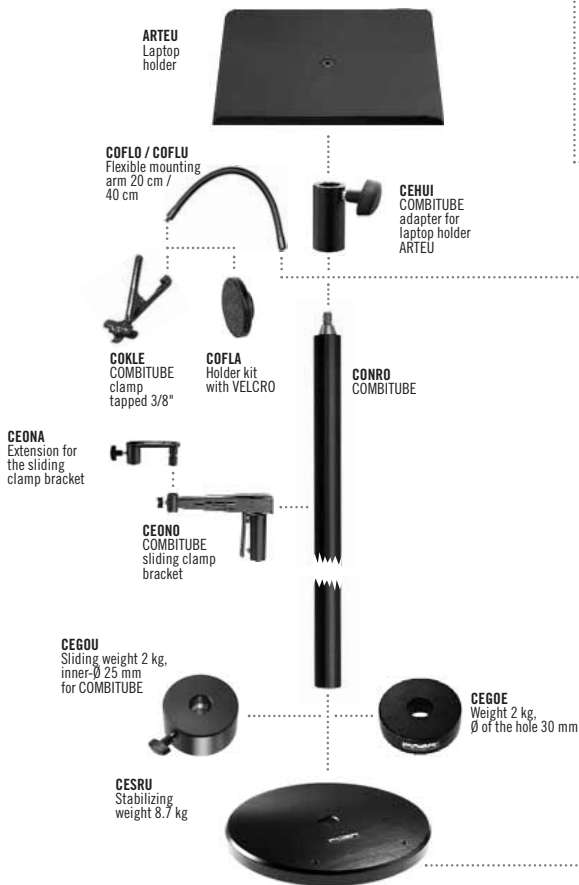

CEBLA BRONCOLOR lamp adapter
CEPRO Adjustable hook fitting



CEBLI All-purpose lamp adapter
COLBE All-purpose adaptor with wing nut
CEBLO insert adapter with 1/4" thread or 3/8" thread



RODEE Lamp adapter with COMBITUBE inner cone
CESTA COMBITUBE top plate with wing nut

Adjustable light stand

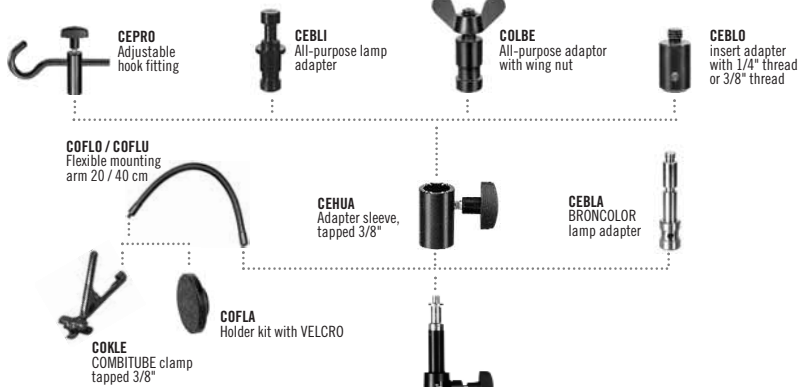

Low lamp stand

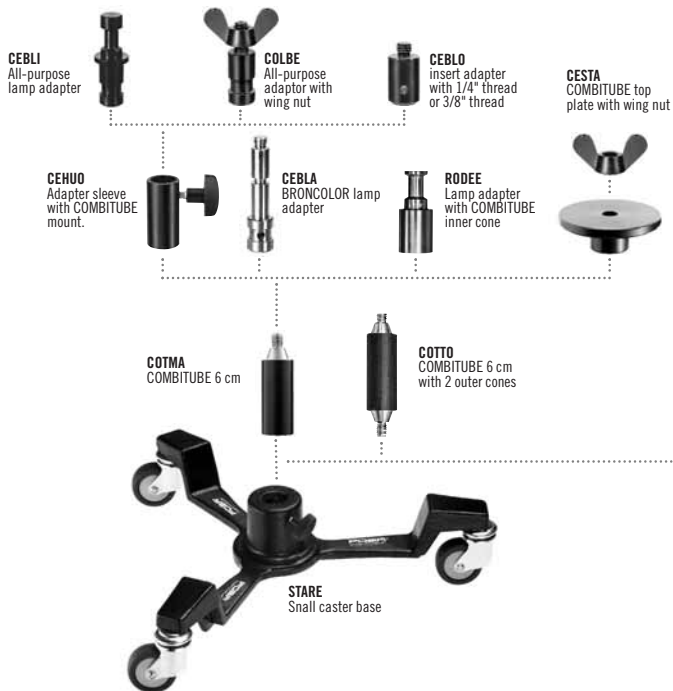

Indestructible: FOBA TT Plast

FOBA **TT Plast** washable plastic background sheets last (almost) forever. Cleaning is no problem with plain or soapy water. FOBA **TT Plast** 100 x 130 cm, 0.3 mm thick sheets are available in 14 different colours. Much appreciated by photographers when they don't want to risk to damage a more delicate background with wet or dirty objects. Available as single sheets rolled up in cardboard box or in set of 1 sheet per colour (product code **F6200**).

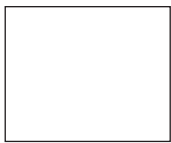

white
F6001



red
F6011

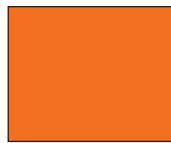

orange
F6021

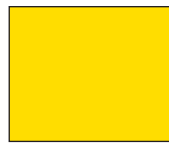

yellow
F6031

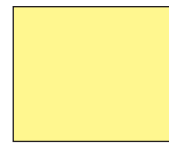

lemon
F6041



light green
F6051



green
F6061



blue
F6071



deep blue
F6081

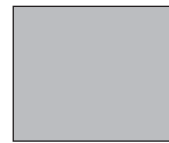

dove grey
F6091



grey
F6101



dark brown
F6111



brown
F6121



black
F6131

FOBA®

STUDIO-TECHNOLOGY

FOBA AG
Studio-Technology
Friedgrabenstrasse 21
CH-8907 Wettswil

☎ +41 44 701 90 00
☎ +41 44 701 90 01

info@foba.com
www.foba.com

FOBA product lines:

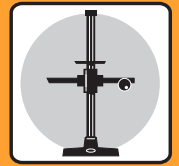

FOBA STUDIO STANDS, TRIPODS
FOBA STATIVE
FOBA PIEDS À COLONNE, TRÉPIEDS



FOBA TRIPOD HEADS
FOBA STATIVKÖPFE
FOBA TÊTES DE TRÉPIEDS

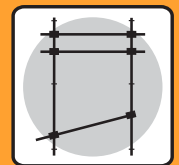

FOBA CEILING RAIL SYSTEM
FOBA DECKENSCHIENEN-SYSTEM
FOBA SYSTEME RAILS DE PLAFOND

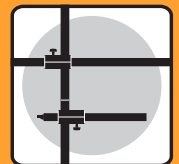

FOBA COMBITUBE SYSTEM
FOBA COMBIROHR® SYSTEM
FOBA SYSTEME COMBITUBE



FOBA BACKGROUND TABLES
FOBA AUFNAHMETISCHE
FOBA TABLES DE PRISE DE VUE